

WEILER®
Food Processing Systems



Grinders



**... Any
Application**

- Coarse Grinding
- Desinewing
- Finish Grinding
- Fresh Raw Material
- Frozen and Tempered Block
- Self-feeding
- Portioning
- Pre-broken Frozen

**... Any
Product**

- Bakery Dough
- Bone
- Canned Meat
- Cheese
- Cooked Smoked Sausage
- Dry Sausage
- Fresh Sausage
- Fruit Paste
- Gelatin
- Ground Meat
- Luncheon Meat
- Petfood
- Uncooked Smoked Sausage
- Yeast

**... Any
Market**

- Bakery
- Dairy
- Fruit and Vegetable
- Meat
- Petfood
- Pharmaceutical
- Poultry
- Rendering
- Seafood

GRINDER CONFIGURATIONS

GRINDER APPLICATION	EQUIPMENT					
	16/12AG	16/19AG	11/10AG	11/10SKG	11/107AG	8/8AG
Bakery Dough					●	●
Bone Collection Reclaim					●	●
Beef Bone		●	●		●	●
Cheese		●			●	●
Coarse Grind Fresh Meat					●	●
Coarse Grind Frozen Block Meat		●			●	
Coarse Grind Pre-broken Frozen Meat		●			●	●
Coarse Grind Tempered Block Meat		●			●	●
Desinewing				●	●	●
Fat		●	●		●	●
Feathers					●	●
Finish Grind		●			●	●
Fish Bone		●	●		●	●
Fruit				●	●	●
Hides		●			●	
Mutton Bone		●	●		●	●
Offal		●	●		●	●
Pork Bone		●	●		●	●
Poultry Bone		●	●		●	●
Poultry Skin		●			●	●
Rendering		●	●		●	●
Seafood				●	●	●
Veal Bone		●	●		●	●
Vegetables				●	●	●
Yeast						●

Performance Proven Grinders ...

Featuring:

- ★ USDA and CE Approval
- ★ Heavy Duty Construction
- ★ 3 or 4 Point Suspension of Grinder to Gearbox
- ★ Tinned or Stainless Steel Construction
- ★ High Capacity Grinding
- ★ Single and Multiple Plate Configurations
- ★ Bone Collection/Removal Options
- ★ Cupped Feedscrew Flights
- ★ Unique Knifeholder Drive System
- ★ Spring-loaded Knifeholders
- ★ Self-sharpening Knife Inserts
- ★ Minimum Temperature Rise
- ★ Improved Finished Product Quality
- ★ Easy Assembly/Disassembly for Sanitation
- ★ Complete Electrical Controls
- ★ Configurations for Specific Applications
- ★ **LOW MAINTENANCE COSTS**

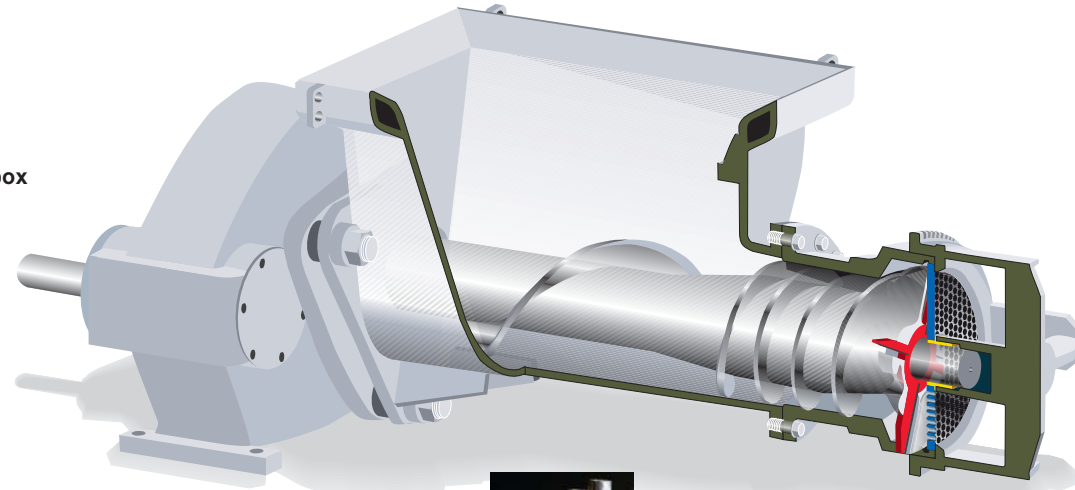

Hand-fabricated Feedscrews incorporate cupped flighting with pitches and depths to match various knife styles and applications.

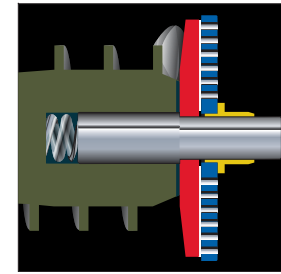

Spring-loaded Knifeholders feature self-sharpening blade inserts for cleaner, cooler cutting and improved product quality.



Feedscrew Drive Lugs are built into the feedscrew for greater drive strength.



Flip-up Hopper Guards allows easy access to grinder hopper and guard for sanitation.



Adjustable Legs allows unit height to be adjusted to accommodate installation requirements.



Genuine Weiler® Replacement Parts available worldwide.



Hopper Guards accommodate standard models and most feeding methods. Custom guards are available.



Ring Lifters and Feedscrew Lift/Pullers available for safe, convenient handling and removal of rings and feedscrews.

Components and Accessories for Maximum Performance and Safety

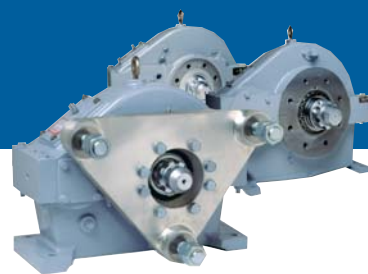

High Thrust, Heavy Duty Gearboxes designed specifically for Weiler® grinders, providing the proper speed and power required for effective, efficient grinding.



Enclosed Gearbox offers improved sanitary design.



Proven Head Designs with straight or spiral flutes and different head lengths to maximize grinder efficiency.



Grinder Plates available in any hole configuration and a variety of plate thicknesses, to fit specific applications.



Precision Crafted Knifeholders available in two, three and four-blade configurations with inexpensive, replaceable inserts or solid edge.



Plate Retaining Rings available with different configurations.



(CBCA)* Continuous Bone Collection Assembly for 11" (280mm) models only. For other models use BCA.



Self-feeding Hoppers eliminate product bridging and assure smooth, even feeding of raw material.

* U.S. Patent Numbers: 5,251,829, 5,289,971, 5,344,086 (Other U.S. and Foreign Patents)

6 Inch (150 mm)



Model 6

- ◆ Coarse Grind
- ◆ Finish Grind
- ◆ Fresh
- ◆ Pre-broken Frozen
- ◆ Tempered Block

3" x 10" x 12" (mm: 75 x 250 x 300)

Raw Materials

- * Bone Collection Reclaim
- * Beef
- * Cheese
- * Fat
- * Mutton
- * Offal
- * Pork
- * Poultry
- * Poultry Bone
- * Poultry Skin
- * Seafood
- * Veal
- * Other

Options:

- ✓ Bone/Tissue Collection Assembly
- ✓ Sidemount Frame
- ✓ Special Hopper Extension
- ✓ Leg Extensions
- ✓ Electrical Controls

6 Technical Data:

- Up to 25 hp (18.5 kw)
- 5 Inch (125 mm) Diameter Feedscrew
- 6 Inch (150 mm) Diameter Plate
- 1362-6HB Heavy-duty Gearbox
- 4-Point Suspension
- Grinding Capacity: to 6,000 lbs (2,722 kg)/hour**
- Approximate Shipping Weight: 1,435 lbs (651 kg)

* NOTE: Dimensions given are for units WITHOUT CE specifications. For certified drawings for installation purposes, contact factory.
** Rate Varies with Application

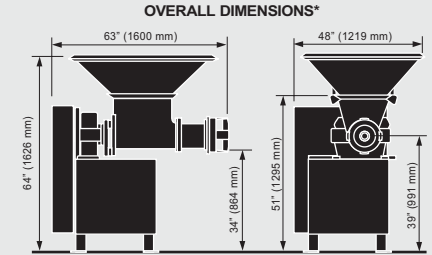

8 5/8 Inch (220 mm)



Model 878

- ◆ Coarse Grind
- ◆ Finish Grind
- ◆ Fresh
- ◆ Pre-broken Frozen
- ◆ Reduction for Mechanical Separators
- ◆ Rendering
- ◆ Tempered and Frozen Block

5" x 14" x 18" (mm: 125 x 350 x 450)

Raw Materials

- * Bone Collection Reclaim
- * Beef
- * Cheese
- * Fat
- * Fruit
- * Mutton
- * Offal
- * Pork
- * Poultry
- * Poultry Bone
- * Poultry Skin
- * Seafood
- * Veal
- * Vegetables
- * Yeast
- * Other

Options: ✓ = Included on all units shipped to CE countries

- ✓ Block Guide
- ✓ Bone/Tissue Collection Assembly
- ✓ Double Plate Assembly (DPA)
- ✓ Electrical Controls
- ✓ FP1000 Feedscrew Lift/Puller
- ✓ 1398-5HB or 1992-5HB Gearbox
- ✓ Head Design
- ✓ Leg Extensions
- ✓ Ring Design
- ✓ Ring Lifter
- ✓ Sidemount Frame
- ✓ Special Hopper Extension
- ✓ Transition Funnel
- ✓ Up to 100 hp (75 kw)

Model 878AG

- ◆ Coarse Grind
- ◆ Finish Grind
- ◆ Fresh



Raw Materials

- * Beef
- * Mutton
- * Pork
- * Poultry
- * Seafood
- * Other
- * Veal
- * Yeast

Options: ✓ = Included on all units shipped to CE countries

- ✓ Bone/Tissue Collection Assembly
- ✓ Double Plate Assembly (DPA)
- ✓ Electrical Controls
- ✓ FP1000 Feedscrew Lift/Puller
- ✓ Leg Extensions
- ✓ Ring Design
- ✓ Ring Lifter
- ✓ Sidemount Frame
- ✓ Special Hopper Extension
- ✓ Transition Funnel

878 Technical Data:

- Up to 50 hp (37 kw)
- 7 Inch (180 mm) Diameter Feedscrew
- 8-5/8 Inch (220 mm) Diameter Plate
- 1780-6HB Heavy-duty Gearbox
- 3-Point Suspension
- Grinding Capacity: to 24,000 lbs (10,887 kg)/Hour**
- Approximate Shipping Weight: 2,350 lbs (1,066 kg)

* NOTE: Dimensions given are for units with CE specifications. All dimensions are for a level grinder in its lowest position. Legs adjust 12" (300 mm) vertical. For certified drawings for installation purposes, contact factory.
** Rate Varies with Application

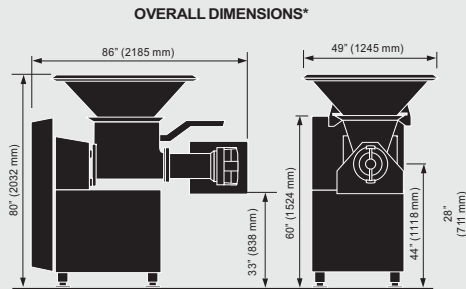

878AG Technical Data:

- 10 Cubic Foot (283 liter) Hopper
- Up to 50 hp (37 kw)
- Self-feeding Paddle System with 1 hp (0.75 kw)
- 7 Inch (180 mm) Diameter Feedscrew
- 8-5/8 Inch (220 mm) Diameter Plate
- 1780-6HB Heavy-duty Gearbox
- 3-Point Suspension
- Grinding capacity: to 15,000 lbs (6,804 kg)/Hour**
- Approximate Shipping Weight: 3,250 lbs (1,474 kg)

* NOTE: Dimensions given are for units WITHOUT CE specifications. For CE unit dimensions or certified drawings for installation purposes, contact factory.
** Rate Varies with Application

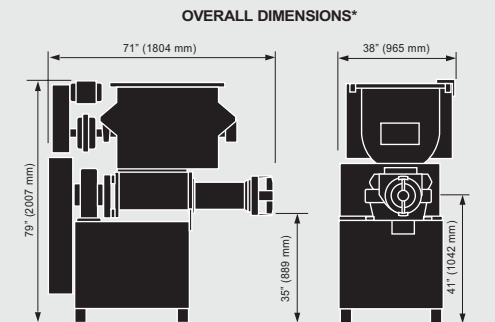

11 Inch (280 mm)

Model 1102

- ◆ Coarse Grind
- ◆ Fresh
- ◆ Reduction for Mechanical Separators
- ◆ Rendering



- Options:** ✓ = Included on all units shipped to CE countries
- ✓ Electrical Controls
 - ✓ FP1000 Feedscrew Lift/Puller
 - ✓ Leg Extensions
 - ✓ Ring Lifter
 - ✓ Sidemount Frame
 - ✓ Special Hopper Extension
 - ✓ Transition Funnel

Raw Materials

- * Bone
- * Beef
- * Fish
- * Mutton
- * Pork
- * Poultry
- * Veal
- * Fat
- * Offal
- * Other

Model 1107

- ◆ Coarse Grind
- ◆ Desinewing
- ◆ Finish Grind
- ◆ Fresh



Raw Materials

- * Bone Collection Reclaim
- * Beef
- * Cheese
- * Fat
- * Fruit
- * Mutton
- * Offal
- * Pork
- * Poultry
- * Poultry Bone
- * Poultry Skin
- * Seafood
- * Veal
- * Vegetables
- * Yeast
- * Other

- Options:** ✓ = Included on all units shipped to CE countries
- ✓ Bone/Tissue Collection Assembly
 - ✓ Desinewing Assembly
 - ✓ Double Plate Assembly (DPA)
 - ✓ Electrical Controls
 - ✓ FP1000 Feedscrew Lift/Puller
 - ✓ Leg Extensions
 - ✓ Ring Design
 - ✓ Ring Lifter
 - ✓ Sidemount Frame
 - ✓ Special Hopper Extension
 - ✓ Transition Funnel

1107 Technical Data:

- Up to 50 hp (37 kw)
- 7 Inch (180 mm) Diameter Feedscrew
- 11 Inch (280 mm) Diameter Plate
- 1780-6HB Heavy-duty Gearbox
- 3-Point Suspension
- Grinding Capacity: to 36,000 lbs (16,330 kg)/Hour**
- Approximate Shipping Weight: 2,350 lbs (1,066 kg)

* NOTE: Dimensions given are for units with CE specifications. All dimensions are for a level grinder in its lowest position. Legs adjust 12" (300 mm) vertical. For certified drawings for installation purposes, contact factory.
** Rate Varies with Application

OVERALL DIMENSIONS*

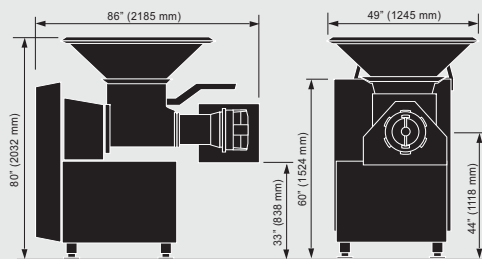

1102 Technical Data:

- Up to 50 hp (37 kw)
- 7 Inch (180 mm) Diameter Feedscrew
- 11 Inch (280 mm) Diameter Plate
- 1780-6HB Heavy-duty Gearbox
- 3-Point Suspension
- Grinding Capacity: to 4,000 lbs (1,815 kg)/Hour**
- Approximate Shipping Weight: 2,350 lbs (1,066 kg)

* NOTE: Dimensions given are for units with CE specifications. All dimensions are for a level grinder in its lowest position. Legs adjust 12" (300 mm) vertical. For certified drawings for installation purposes, contact factory.
** Rate Varies with Application

OVERALL DIMENSIONS*

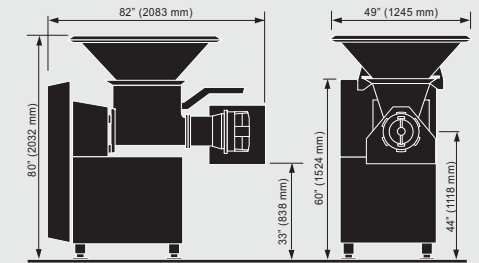

Model 1107AG

- ◆ Coarse Grind
- ◆ Desinewing
- ◆ Finish Grind
- ◆ Fresh



Raw Materials

- * Beef
- * Mutton
- * Pork
- * Poultry
- * Seafood
- * Veal
- * Yeast
- * Other

- Options:** ✓ = Included on all units shipped to CE countries
- ✓ Bone/Tissue Collection Assembly
 - ✓ Desinewing Assembly
 - ✓ Double Plate Assembly (DPA)
 - ✓ Electrical Controls
 - ✓ FP1000 Feedscrew Lift/Puller
 - ✓ Leg Extensions
 - ✓ Ring Design
 - ✓ Ring Lifter
 - ✓ Sidemount Frame
 - ✓ Special Hopper Extension
 - ✓ Transition Funnel



1107AG Technical Data:

- 10 Cubic Foot (283 liter) Hopper
- Up to 50 hp (37 kw)
- Self-feeding Paddle System with 1 hp (0.75 kw)
- 7 Inch (180 mm) Diameter Feedscrew
- 11 Inch (280 mm) Diameter Plate
- 1780-6HB Heavy-duty Gearbox
- 3-Point Suspension
- Grinding Capacity: to 21,000 lbs (9,526 kg)/Hour**
- Approximate Shipping Weight: 3,250 lbs (1,474 kg)

* NOTE: Dimensions given are for units WITHOUT CE specifications. For CE unit dimensions or certified drawings for installation purposes, contact factory.
** Rate Varies with Application

OVERALL DIMENSIONS*

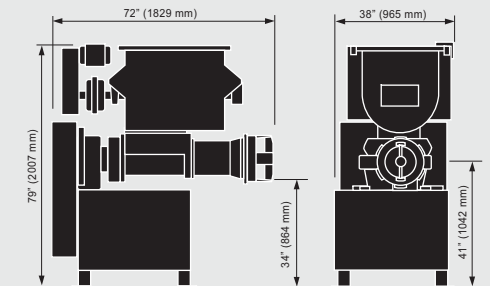

11 Inch (280 mm)



Model 1109

- ◆ Coarse Grind
 - ◆ Desinewing
 - ◆ Finish Grind
 - ◆ Fresh
 - ◆ Pre-broken Frozen
 - ◆ Reduction for Mechanical Separators
 - ◆ Rendering
 - ◆ Tempered and Frozen Block
- 6" x 15" x 22" (mm: 150 x 375 x 550)



Raw Materials

- * Bone Collection Reclaim
- * Beef
- * Cheese
- * Fat
- * Feathers
- * Fruit
- * Hides
- * Mutton
- * Yeast
- * Offal
- * Pork
- * Poultry
- * Poultry Skin
- * Seafood
- * Veal
- * Vegetables
- * Other
- * Bone
- * Beef
- * Fish
- * Mutton
- * Pork
- * Poultry
- * Veal

Options:

✓ = Included on all units shipped to CE countries

- ✓ Block Guide
- ✓ Bone/Tissue Collection Assembly
- ✓ Desinewing Assembly
- ✓ Double Plate Assembly (DPA)
- ✓ Electrical Controls
- ✓ FP1000 Feedscrew Lift/Puller
- ✓ 16123-5HC Gearbox
- ✓ Head Design
- ✓ Leg Extensions
- ✓ Ring Design
- ✓ Ring Lifter
- ✓ Sidemount Frame
- ✓ Special Hopper Extension
- ✓ Transition Funnel
- ✓ Triple Plate Assembly (TPA)
- ✓ Up to 150 hp (110 kw)

1109 Technical Data:

- Up to 100 hp (75 kw)
- 9 Inch (230 mm) Diameter Feedscrew
- 11 Inch (280 mm) Diameter Plate
- 1398-5HB or 1992-5HB Heavy-duty Gearbox
- 3-Point Suspension
- Grinding Capacity: to 72,000 lbs (32,660 kg)/Hour**
- Approximate Shipping Weight: 3,820 lbs (1,733 kg)

OVERALL DIMENSIONS*

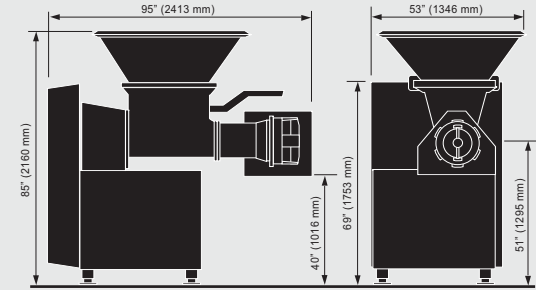

* NOTE: Dimensions given are for units with CE specifications. All dimensions are for a level grinder in its lowest position. Legs adjust 12" (300 mm) vertical. For certified drawings for installation purposes, contact factory.
** Rate Varies with Application



Model 1109SFG

- ◆ Coarse Grind
- ◆ Desinewing
- ◆ Finish Grind
- ◆ Fresh

Raw Materials

- * Beef
- * Mutton
- * Pork
- * Poultry
- * Seafood
- * Other
- * Veal
- * Yeast

Options:

✓ = Included on all units shipped to CE countries

- ✓ Bone/Tissue Collection Assembly
- ✓ Desinewing Assembly
- ✓ Double Plate Assembly (DPA)
- ✓ Electrical Controls
- ✓ FP1000 Feedscrew Lift/Puller
- ✓ Leg Extensions
- ✓ Ring Design
- ✓ Ring Lifter
- ✓ Special Hopper Extension
- ✓ Transition Funnel

1109SFG Technical Data:

- 50 Cubic Foot (1,416 liter) Hopper
- Up to 100 hp (75 kw)
- Self-feeding Paddle System with 5 hp (4 kw)
- 9 Inch (230 mm) Diameter Feedscrew
- 11 Inch (280 mm) Diameter Plate
- 1398-5HB or 1992-5HB Heavy-duty Gearbox
- 3-Point Suspension
- Grinding Capacity: to 21,000 lbs (9,526 kg)/Hour**
- Approximate Shipping Weight: 5,600 lbs (2,541 kg)

OVERALL DIMENSIONS*

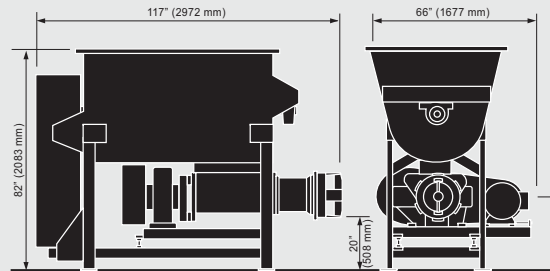

NOTE: The model 1109SFG normally requires a subframe to increase the discharge height in order to accommodate standard carts and conveyors.

* NOTE: Dimensions given are for units WITHOUT CE specifications. For CE unit dimensions or certified drawings for installation purposes, contact factory.
** Rate Varies with Application



Model 1109AG

- ◆ Coarse Grind
- ◆ Desinewing
- ◆ Finish Grind
- ◆ Fresh

Raw Materials

- * Beef
- * Mutton
- * Pork
- * Poultry
- * Seafood
- * Veal
- * Yeast
- * Other

Options:

✓ = Included on all units shipped to CE countries

- ✓ Bone/Tissue Collection Assembly
- ✓ Desinewing Assembly
- ✓ Double Plate Assembly (DPA)
- ✓ Electrical Controls
- ✓ FP1000 Feedscrew Lift/Puller
- ✓ Leg Extensions
- ✓ Ring Design
- ✓ Ring Lifter
- ✓ Sidemount Frame
- ✓ Special Hopper Extension
- ✓ Transition Funnel
- ✓ 20 Cubic Foot (566 liter) Hopper with 2 hp (1.5 kw) Motor

1109AG Technical Data:

- 10 Cubic Foot (283 liter) Hopper
- Up to 100 hp (75 kw)
- Self-feeding Paddle System with 1 hp (0.75 kw)
- 9 Inch (230 mm) Diameter Feedscrew
- 11 Inch (280 mm) Diameter Plate
- 1398-5HB or 1992-5HB Heavy-duty Gearbox
- 3-Point Suspension
- Grinding Capacity: to 21,000 lbs (9,526 kg)/Hour**
- Approximate Shipping Weight: 4,820 lbs (2,187 kg)

OVERALL DIMENSIONS*

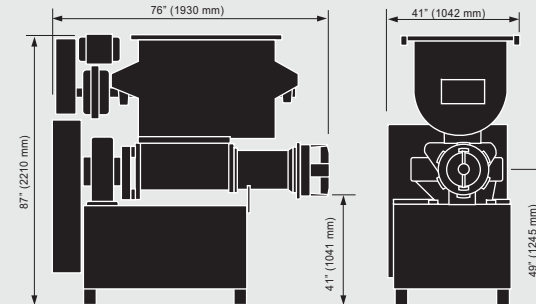

* NOTE: Dimensions given are for 10 cubic foot units WITHOUT CE specifications. For CE unit dimensions or certified drawings for installation purposes, contact factory. Overall dimensions for 20 cubic foot model are slightly larger.
** Rate Varies with Application

16 Inch (400 mm)

Model 1609

- ◆ Coarse Grind
- ◆ Rendering

Raw Materials		
* Bone	* Pork	* Fat
• Beef	• Poultry	* Offal
• Fish	• Veal	* Other
• Mutton		



Options: ✓ = Included on all units shipped to CE countries

- ✓ Electrical Controls
- ✓ FP1000 Feedscrew Lift/Puller
- ✓ Leg Extensions
- ✓ Ring Lifter
- ✓ Sidemount Frame
- ✓ Special Hopper Extension

1609 Technical Data:

- Up to 100 hp (75 kw)
- 9 Inch (230 mm) Diameter Feedscrew
- 16 Inch (400 mm) Diameter Plate
- 1398-5HB Heavy-duty Gearbox
- 3-Point Suspension
- Grinding Capacity: to 20,000 lbs (9,072 kg)/Hour**
- Approximate Shipping Weight: 4,065 lbs (1,844 kg)

* NOTE: Dimensions given are for units WITHOUT CE specifications. For CE unit dimensions or certified drawings for installation purposes, contact factory.
** Rate Varies with Application

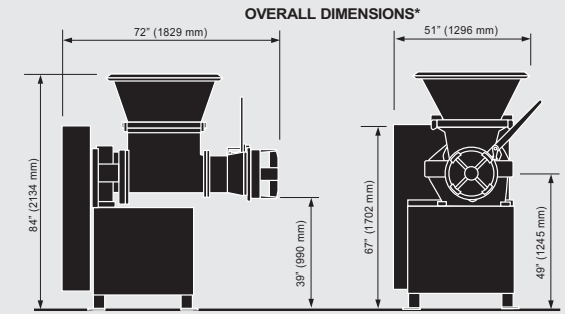

Model 1666

- ◆ Coarse Grind
- ◆ Rendering

Raw Materials		
* Bone	* Pork	* Fat
• Beef	• Poultry	* Other
• Fish	• Veal	
• Mutton		



Options: ✓ = Included on all units shipped to CE countries

- ✓ Electrical Controls
- ✓ FP1000 Feedscrew Lift/Puller
- ✓ Leg Extensions
- ✓ Ring Lifter
- ✓ Sidemount Frame
- ✓ Special Hopper Extension

Model 1612

- ◆ Coarse Grind
- ◆ Finish Grind
- ◆ Fresh
- ◆ Pre-broken Frozen
- ◆ Rendering
- ◆ Tempered and Frozen Block
9" x 18" x 24" (mm: 230 x 450 x 600)

Raw Materials		
* Beef	* Poultry	* Bone
* Fat	* Poultry Skin	• Beef
* Fruit	* Seafood	• Fish
* Hides	* Veal	• Mutton
* Mutton	* Vegetables	• Pork
* Pork	* Other	• Poultry
		• Veal



Options: ✓ = Included on all units shipped to CE countries

- ✓ Block Guide
- ✓ Electrical Controls
- ✓ FP1000 Feedscrew Lift/Puller
- ✓ Head Design
- ✓ Leg Extensions
- ✓ Ring Lifter
- ✓ Sidemount Frame
- ✓ Special Hopper Extension

1666 Technical Data:

- Up to 100 hp (75 kw)
- 9 Inch (230 mm) Diameter Feedscrew
- 16 Inch (400 mm) Diameter Plate
- 1398-5HB Heavy-duty Gearbox
- 3-Point Suspension
- Grinding Capacity: to 25,000 lbs (11,340 kg)/Hour**
- Approximate Shipping Weight: 4,065 lbs (1,844 kg)

* NOTE: Dimensions given are for units WITHOUT CE specifications. For CE unit dimensions or certified drawings for installation purposes, contact factory.
** Rate Varies with Application

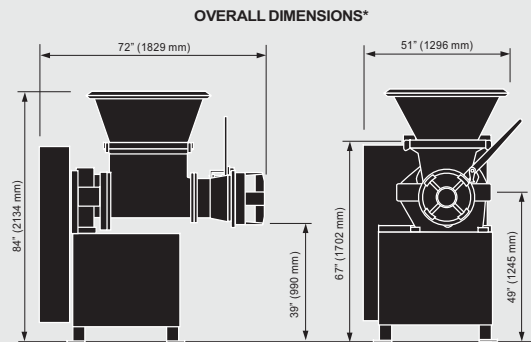

1612 Technical Data:

- Up to 200 hp (150 kw)
- 12 Inch (300 mm) Diameter Feedscrew
- 16 Inch (400 mm) Diameter Plate
- 16123-5HC Heavy-duty Gearbox
- 3-Point Suspension
- Grinding Capacity: to 40,000 lbs (18,144 kg)/Hour**
- Approximate Shipping Weight: 6,800 lbs (3,085 kg)

* NOTE: Dimensions given are for units with CE specifications. All dimensions are for a level grinder in its lowest position. Legs adjust 12" (300 mm) vertical. For certified drawings for installation purposes, contact factory.
** Rate Varies with Application

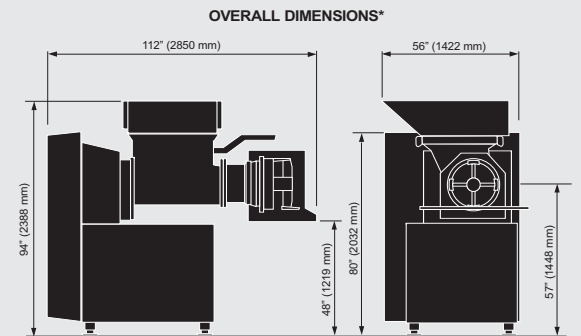

Worldwide Customer Service



To Serve You Better

- **Genuine Replacement Parts**
- **Application Engineering**
- **Technical and Maintenance Support**
- **Feedscrew Exchange Program**
- **Factory Rebuilding of Parts and Equipment**
- **Test Laboratory**
- **Partnership in New Product Development**
- **Installation, Commissioning and Training**
- **Worldwide Representation Network**

WEILER® and Company, Inc.

www.weilerinc.com email: sales@weilerinc.com

Corporate Headquarters: Whitewater, Wisconsin 53190 U.S.A.

USA: 262-473-5254 • 800-558-9507 • Fax: 262-473-5867 • Europe: +44 (0) 1454 320900 • Fax: +44 (0) 1454 326262

Grinders • Mixers • Conveyors • Mixer Grinders • Separators • Complete Systems